

**WIPER CONTROLLER  
SYSTEM**

**CT12**

**MOTOR BRAKE**

*User's manual*

 **PINE** s.r.l.

**MARINE DIVISION**

CT12 - 2 TERGICRISTALLI  
CT12 - 2 WIPERS

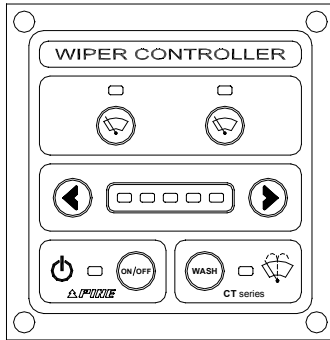

CT13 - 3 TERGICRISTALLI  
CT13 - 3 WIPERS

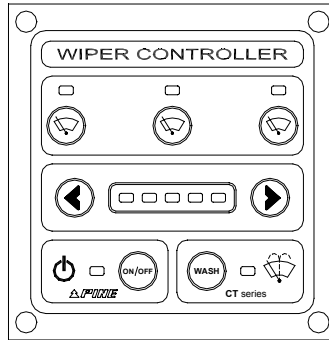

CT14 - 4 TERGICRISTALLI  
CT14 - 4 WIPERS

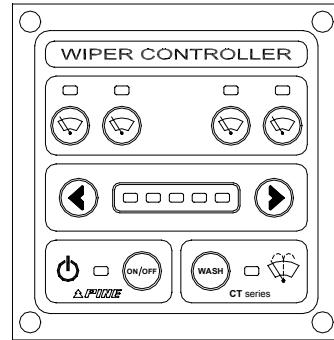

CT15 - 5 TERGICRISTALLI  
CT15 - 5 WIPERS

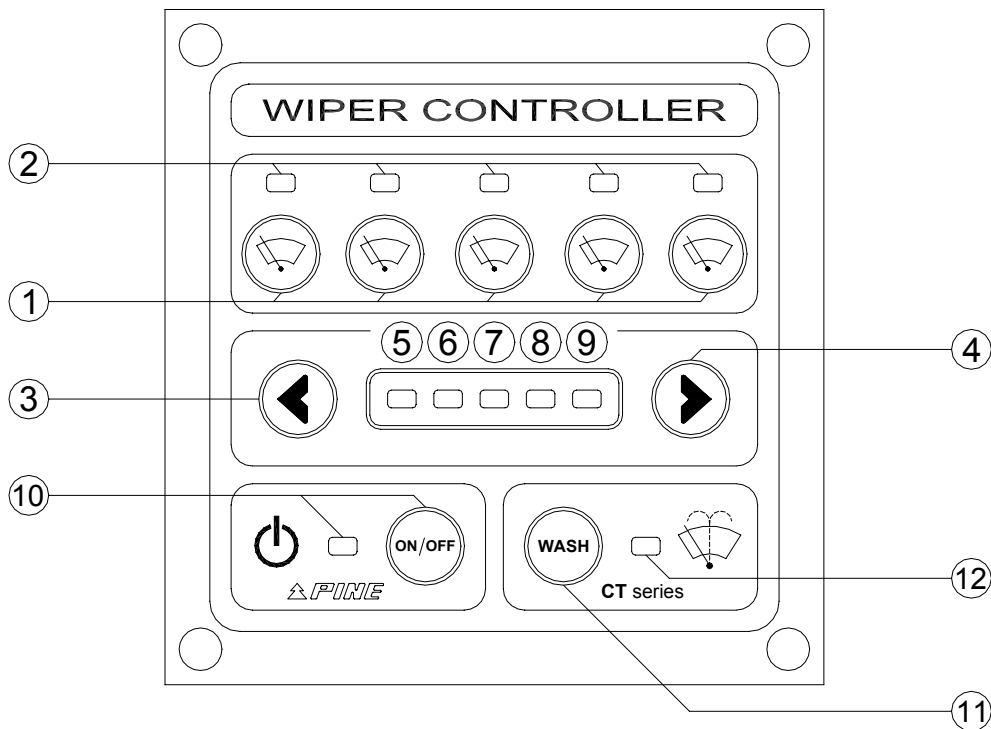

Fig. 1 - SERIE CT10  
Fig. 1 - CT10 SERIES

## **1. OVERVIEW**

**CT10** is a wiper controller electronic unit based on microprocessor. It drives from **one** up to **five** wipers **synchronized together**, and it's provided with an automatic windscreen washing program.

Wipers can be managed by a single On/Off key, or independently.

Brush can be continuous or intermittent, depending on User's timing regulation.

CT10 control unit must be placed on the ship pilot bridge, or alternatively on a board protecting the back against water. **D3** and **D4** drawings show cutting for a correct assembly.

Electrical schemes and connector numbering are on **D1** and **D2** drawings.

It is advisable to use an appropriate wire size depending on motor consumption, protecting lines by fuses.

### **General features:**

- Up to five wipers synchronized together (\*);
- General On/Off key + 5 keys to manage every single wiper (\*);
- 4 timing regulations (intermittent mode);
- Selected function mode visualized by 5-LED bar;
- One-touch key washing program;
- "Low windscreen liquid level" and "parking switch damaged" warning lamps;
- 12V or 24V power supply – CT10 unit size: 98 x 100 mm.

(\*) The number of wipers managed by CT10 unit depends on User's configuration required.

### **Signaling and commands:**

With reference to figure 1:

- 1 - Single wiper On/Off key;
- 2 - Related wiper lamp;
- 3 - Increase waiting time for brush;
- 4 - Decrease waiting time for brush;
- 5 - 12 s waiting time lamp;
- 6 - 8 s waiting time lamp;
- 7 - 4 s waiting time lamp;
- 8 - 2 s waiting time lamp;
- 9 - Continuous mode lamp;
- 10 - General On/Off key and related lamp;
- 11 - One-touch washing program key;
- 12 - Washing program lamp / Low windscreen liquid level lamp.

## **2. UNIT SWITCHING-ON**

A lamp test is executed.

If a wiper is in the middle of the windscreen, CT10 drives it until the parking zone is reached.

Pressing key (10), all wipers start to brush and related lamps (2) go on;

LED bar (5..9) indicates function mode. User can change it by keys (3) and (4).

Press key (10) again to stop brushes. It is possible to manage every single wiper using its key (1).

Note: When User turns off system, wipers don't stop immediately because they have to reach the parking zone first.

### **3. WAITING TIME IN INTERMITTENT MODE**

Time needed between one brush and another is called “waiting time”.

Waiting time is visualized by LED bar (5..9).

LED BAR STATE	WAITING TIME	WORKING MODE
1 lamp on (5)	12 seconds	intermittent
2 lamps on (5+6)	8 seconds	intermittent
3 lamps on (5+6+7)	4 seconds	intermittent
4 lamps on (5+6+7+8)	2 seconds	intermittent
all LED bar on (5+6+7+8+9)	-	continuous and synchronized

### **4. WINDSCREEN CLEANING**

CT10 allows an automatic windscreen washing program by the one-touch key (11):

- wipers in the middle of the windscreen come back to parking zone;
- washing pump turns on, and brushes start;
- washing pump turns off, but wipers still stay on for a couple of brushes more.

Keeping key (11) pressed, washing pump stays on longer.

Once the washing program stops, CT10 come back to previous function automatically.

CT10 is provided with a pump output pin, and a “low liquid level” warning lamp (12) driven by an On/Off switch installed in the liquid reservoir.

LAMP (12) STATE	MEANING	REMARKS
off	system off / reservoir full	normal working
on	washing program is running	normal working
blinking	low liquid level	fill up the reservoir

Note: when CT10 unit is off, lamp (12) stays off too, even if liquid reservoir is empty.

### **5. AUTOMATIC PARKING SWITCH**

This kind of switch works to move wiper to parking zone. If parking switch is damaged, the followings happen:

- Lamp (2) related to the damaged parking switch starts to blink;
- Wiper can be managed anyway, but parking zone does not exist anymore;
- Synchronization with other wipers is denied because parking switch is needed.

### **6. EXCLUDING SOME WIPERS FROM WASHING PROGRAM**

User can exclude some wipers from washing program:

- Supply CT10 and press both keys (3) and (4) for few seconds, until LED bar blinks;
- Press now key (1) corresponding to wiper User wants to exclude: related lamp (2) turns off;
- Press On/Off key (10) to store in memory User’s change.

It is possible to undo the procedure and enable some wipers following the same rules just explained, but lamp (2) has to stay on instead of off.

## 7. TECHNICAL SPECIFICATIONS

<b>CT10 Series WIPER CONTROLLER</b>		
Power supply	12Vcc min 8V, max 15V	24Vcc min 16V, max 30V
Stand-by power consumption	Less than 4W	
Protections	Polarity inversion, Battery disconnecting extravoltage (not repetitive)	
Temperature	-10 °C / +60 °C (working)	-30°C / +70 °C (storage)
Lamps	General On/Off lamp Wiper state / Parking switch damaged LED bar for wiper temporization Washing program / low windscreen liquid level	
Acoustic indication	Internal buzzer	
Digital inputs	From 1 up to 5 parking switch Low liquid level On/Off switch	
Outputs	From 1 up to 5 power-relay driver (2 outputs only for CT11) 1 washing pump (Imax = 1A positive output, negative on request) 1 motor brake management (CT12-5 only)	
Operating mode	4 intermittent timing levels not linear (min 2 s, max 12 s) 1 continuous synchronized	
Size	98 x 100 mm – Side screws: 3MA head-flare	

<b>SR20 REMOTE RELAY-BOX (CT12-5 only)</b>	
Power supply and temperature	See previous table
Inputs	15P Male Mate'N'Lock connector Power supply, washing pump and "low level" On/Off switch.
Outputs	4P terminal each motor, max 16A @ 14Vdc / 8A @ 24Vdc
CT/SR wire connection CODE	CAVOCT0901 (CT12) / CAVOCT1501 (CT13-5)

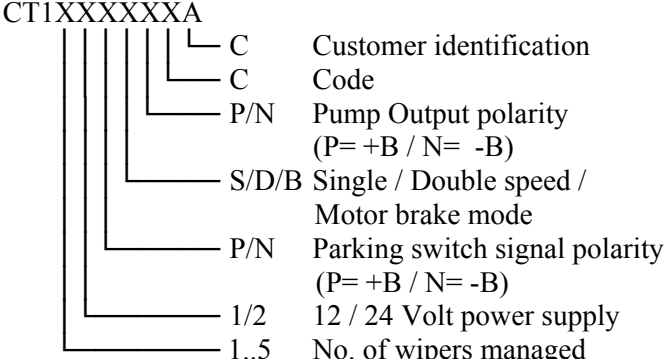
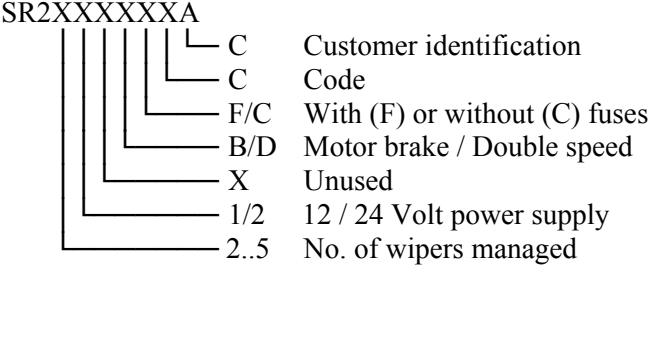
<b>CT10 UNIT DESCRIPTION CODE</b>	<b>SR20 RELAY BOX DESCRIPTION CODE</b>
<p>CT1XXXXXXXXA</p>  <ul style="list-style-type: none"> <li>C Customer identification</li> <li>C Code</li> <li>P/N Pump Output polarity (P= +B / N= -B)</li> <li>S/D/B Single / Double speed / Motor brake mode</li> <li>P/N Parking switch signal polarity (P= +B / N= -B)</li> <li>1/2 12 / 24 Volt power supply</li> <li>1..5 No. of wipers managed</li> </ul>	<p>SR2XXXXXXXXA</p>  <ul style="list-style-type: none"> <li>C Customer identification</li> <li>C Code</li> <li>F/C With (F) or without (C) fuses</li> <li>B/D Motor brake / Double speed</li> <li>X Unused</li> <li>1/2 12 / 24 Volt power supply</li> <li>2..5 No. of wipers managed</li> </ul>

## 8. CONFORMITY DECLARATION



Manufacturer declares this product complies with european requirements for electromagnetic compatibility, as required from 89/366/EEC, 73/33/EEC and EN60945 directives.





# SERIE / SERIES SR20

SR221XBFXA (12V)  
 SR222XBFXA (24V)

VISTA DA SOTTO  
 BOTTOM VIEW

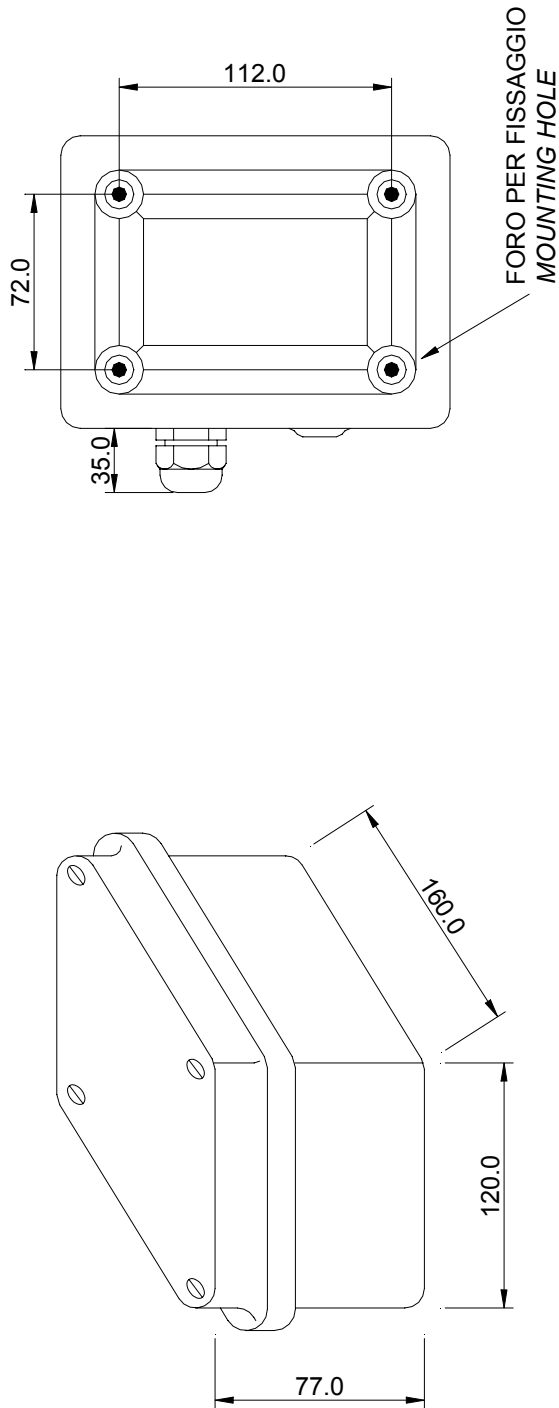

RIF. FILE / FILE REF. : DSDXT12D3A CODICE / CODE :	DATA / DATE : 07/06/2002	DESCRIZIONE / DESCRIPTION : SR20 : DIMENSIONI E DIMA DI FORATURA SR20 : SIZE AND CUTTING EDGE		DISEGNATO / DESIGNED : DA RE L. APPROVATO / APPROVED : BOSCARATO A.
	REV. / REV. : A	FOGLIO / SHEET : D3	<b>PINE S.r.l.</b> Chioggia (VE) - Italy	

**SERIE / SERIES CT10**

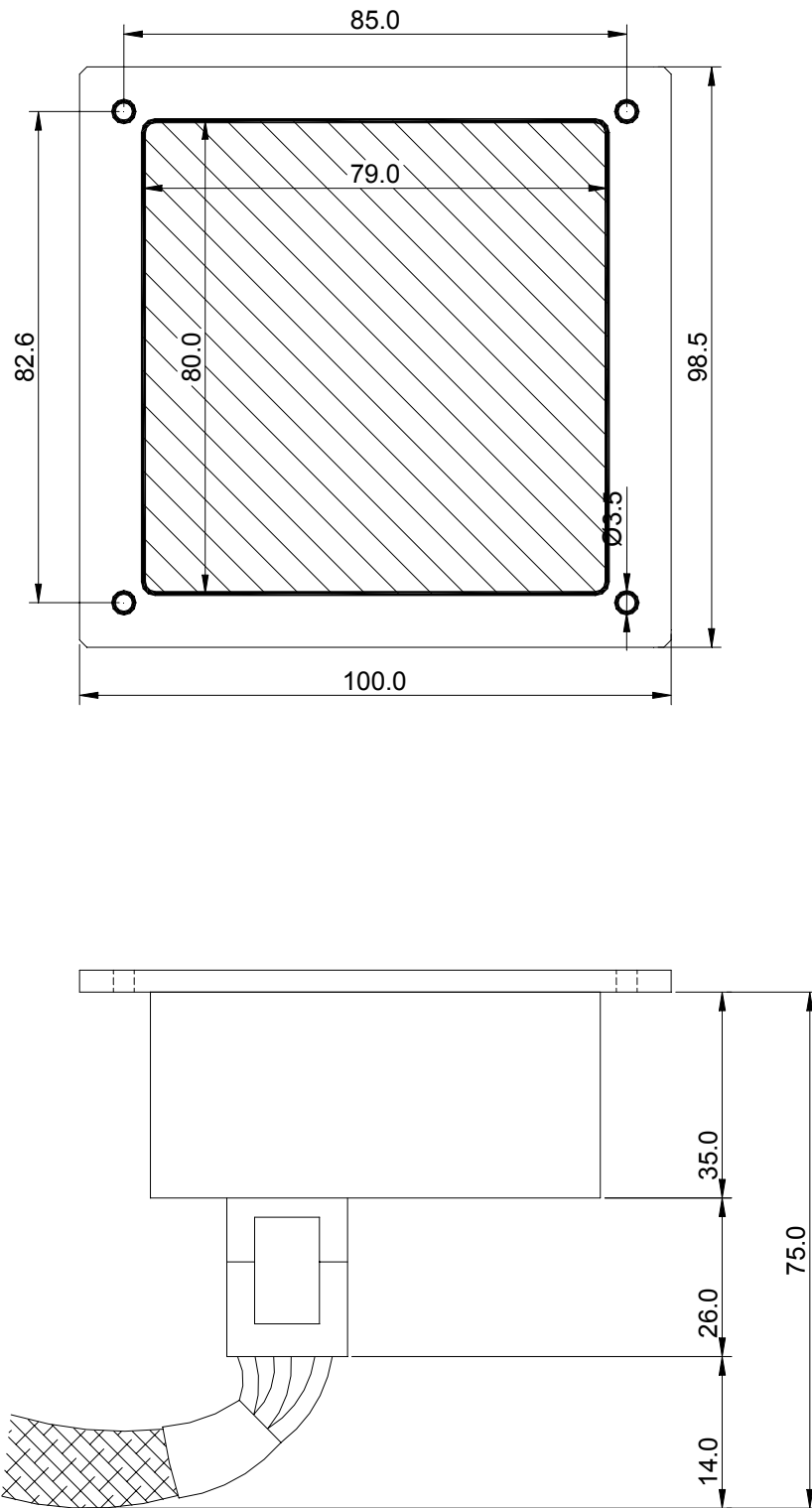

RIF. FILE / FILE REF. :		DATA / DATE :		DESCRIZIONE / DESCRIPTION :		DISEGNATO / DESIGNED :	
DSDXT10D4A		07/06/2002		CT10 : DIMENSIONI E DIMA DI FORATURA CT10 : SIZE AND CUTTING EDGE		DA REL.	
CODICE / CODE :		REV. / REV. :				APPROVATO / APPROVED :	
DSDXT10D4A		A		D4		BOSCARATO A.	



Registered Office : Via P. E. Venturini, 56 - 30015 Chioggia (VE) - Italy

Head Office : Via D. Schiavo 181 - 30019 Sottomarina (VE) - Italy

Telephone +39.041.55.44.862 - Fax +39.041.55.43.194

[www.pinesrl.com](http://www.pinesrl.com) - [info@pinesrl.com](mailto:info@pinesrl.com)